

## Package leaflet: Information for the patient

### Humira 40 mg solution for injection in pre-filled pen adalimumab

**Read all of this leaflet carefully before you start using this medicine because it contains important information for you.**

- Keep this leaflet. You may need to read it again.
- Your doctor will also give you a Patient Alert Card, which contains important safety information that you need to be aware of before you are given Humira and during treatment with Humira. Keep this Patient Alert Card with you.
- If you have any further questions, ask your doctor or pharmacist.
- This medicine has been prescribed for you only. Do not pass it on to others. It may harm them, even if their signs of illness are the same as yours.
- If you get any side effects, talk to your doctor or pharmacist. This includes any possible side effects not listed in this leaflet (see section 4).

#### **What is in this leaflet:**

1. What Humira is and what it is used for
2. What you need to know before you use Humira
3. How to use Humira
4. Possible side effects
5. How to store Humira
6. Contents of the pack and other information

#### **1. What Humira is and what it is used for**

Humira contains the active substance adalimumab, a selective immunosuppressive agent. Humira is intended for treatment of rheumatoid arthritis, polyarticular juvenile idiopathic arthritis, enthesitis-related arthritis, ankylosing spondylitis, axial spondyloarthritis without radiographic evidence of ankylosing spondylitis, psoriatic arthritis, psoriasis, hidradenitis suppurativa, Crohn's disease, ulcerative colitis and non-infectious uveitis affecting the back of the eye. It is a medicine that decreases the inflammation process of these diseases. The active ingredient, adalimumab, is a human monoclonal antibody produced by cultured cells. Monoclonal antibodies are proteins that recognise and bind to other unique proteins. Adalimumab binds to a specific protein (tumour necrosis factor or TNF $\alpha$ ), which is present at increased levels in inflammatory diseases such as rheumatoid arthritis, polyarticular juvenile idiopathic arthritis, enthesitis-related arthritis, ankylosing spondylitis, axial spondyloarthritis without radiographic evidence of ankylosing spondylitis, psoriatic arthritis, psoriasis, hidradenitis suppurativa, Crohn's disease, ulcerative colitis and non-infectious uveitis affecting the back of the eye.

#### Rheumatoid arthritis

Rheumatoid arthritis is an inflammatory disease of the joints.

Humira is used to treat rheumatoid arthritis in adults. If you have moderate to severe active rheumatoid arthritis, you may first be given other disease-modifying medicines, such as methotrexate. If you do not respond well enough to these medicines, you will be given Humira to treat your rheumatoid arthritis.

Humira can also be used to treat severe, active and progressive rheumatoid arthritis without previous methotrexate treatment.

Humira has been shown to slow down the damage to the cartilage and bone of the joints caused by the disease and to improve physical function.

Usually, Humira is used with methotrexate. If your doctor determines that methotrexate is inappropriate, Humira can be given alone.

#### Polyarticular juvenile idiopathic arthritis and enthesitis-related arthritis

Polyarticular juvenile idiopathic arthritis and enthesitis-related arthritis are inflammatory diseases.

Humira is used to treat polyarticular juvenile idiopathic arthritis in children and adolescents aged 2 to 17 years and enthesitis-related arthritis in children and adolescents aged 6 to 17 years. You may first be given other disease-modifying medicines, such as methotrexate. If you do not respond well enough to these medicines, you will be given Humira to treat your polyarticular juvenile idiopathic arthritis or enthesitis-related arthritis.

#### Ankylosing spondylitis and axial spondyloarthritis without radiographic evidence of ankylosing spondylitis

Ankylosing spondylitis and axial spondyloarthritis without radiographic evidence of ankylosing spondylitis, are inflammatory diseases of the spine.

Humira is used to treat ankylosing spondylitis and axial spondyloarthritis without radiographic evidence of ankylosing spondylitis in adults. If you have ankylosing spondylitis or axial spondyloarthritis without radiographic evidence of ankylosing spondylitis, you will first be given other medicines. If you do not respond well enough to these medicines, you will be given Humira to reduce the signs and symptoms of your disease.

#### Psoriatic arthritis

Psoriatic arthritis is an inflammation of the joints associated with psoriasis.

Humira is used to treat psoriatic arthritis in adults. Humira has been shown to slow down the damage to the cartilage and bone of the joints caused by the disease and to improve physical function.

#### Plaque psoriasis in adults and children

Plaque psoriasis is a skin condition that causes red, flaky, crusty patches of skin covered with silvery scales. Psoriasis is believed to be caused by a problem with the body's immune system that leads to an increased production of skin cells.

Humira is used to treat moderate to severe plaque psoriasis in adults. Humira is also used to treat severe plaque psoriasis in children and adolescents aged 4 to 17 years for whom topical therapy and phototherapies have either not worked very well or are not suitable.

#### Hidradenitis suppurativa

Hidradenitis suppurativa (sometimes called acne inversa) is a chronic and often painful inflammatory skin disease. Symptoms may include tender nodules (lumps) and abscesses (boils) that may leak pus. It most commonly affects specific areas of the skin, such as under the breasts, the armpits, inner thighs, groin and buttocks. Scarring may also occur in affected areas.

Humira is used to treat hidradenitis suppurativa in adults. Humira can reduce the number of nodules and abscesses you have, and the pain that is often associated with the disease.

## Crohn's disease in adults and children

Crohn's disease is an inflammatory disease of the digestive tract.

Humira is used to treat Crohn's disease in adults and children aged 6 to 17 years. If you have Crohn's disease you will first be given other medicines. If you do not respond well enough to these medicines, you will be given Humira to reduce the signs and symptoms of your Crohn's disease.

## Ulcerative colitis

Ulcerative colitis is an inflammatory disease of the bowel.

Humira is used to treat ulcerative colitis in adults. If you have ulcerative colitis you will first be given other medicines. If you do not respond well enough to these medicines, you will be given Humira to reduce the signs and symptoms of your disease.

## Non-infectious uveitis affecting the back of the eye

Non-infectious uveitis is an inflammatory disease affecting certain parts of the eye.

Humira is used to treat adults with non-infectious uveitis with inflammation affecting the back of the eye. This inflammation leads to a decrease of vision and/or the presence of floaters in the eye (black dots or wispy lines that move across the field of vision). Humira works by reducing this inflammation.

## **2. What you need to know before you use Humira**

### **Do not use Humira**

- If you are allergic to adalimumab or any of the other ingredients of this medicine (listed in section 6).
- If you have a severe infection, including active tuberculosis (see "Warnings and precautions"). It is important that you tell your doctor if you have symptoms of infections, e.g. fever, wounds, feeling tired, dental problems.
- If you have moderate or severe heart failure. It is important to tell your doctor if you have had or have a serious heart condition (see "Warnings and precautions").

### **Warnings and precautions**

Talk to your doctor or pharmacist before using Humira

- If you experience allergic reactions with symptoms such as chest tightness, wheezing, dizziness, swelling or rash do not inject more Humira and contact your doctor immediately.
- If you have an infection, including long-term or localized infection (for example, leg ulcer) consult your doctor before starting Humira. If you are unsure, please contact your doctor.
- You might get infections more easily while you are receiving Humira treatment. This risk may increase if your lung function is impaired. These infections may be serious and include tuberculosis, infections caused by viruses, fungi, parasites or bacteria, or other opportunistic infections and sepsis that may, in rare cases, be life-threatening. It is important to tell your doctor if you get symptoms such as fever, wounds, feeling tired or dental problems. Your doctor may recommend temporary discontinuation of Humira.

- As cases of tuberculosis have been reported in patients treated with Humira, your doctor will check you for signs and symptoms of tuberculosis before starting Humira. This will include a thorough medical evaluation including your medical history and appropriate screening tests (for example chest X-ray and a tuberculin test). The conduct and results of these tests should be recorded on your Patient Alert Card. It is very important that you tell your doctor if you have ever had tuberculosis, or if you have been in close contact with someone who has had tuberculosis. Tuberculosis can develop during therapy even if you have received preventative treatment for tuberculosis. If symptoms of tuberculosis (persistent cough, weight loss, listlessness, mild fever), or any other infection appear during or after therapy tell your doctor immediately.
- Advise your doctor if you reside or travel in regions where fungal infections such as histoplasmosis, coccidioidomycosis or blastomycosis are endemic.
- Advise your doctor if you have a history of recurrent infections or other conditions that increase the risk of infections.
- Advise your doctor if you are a carrier of the hepatitis B virus (HBV), if you have active HBV or if you think you might be at risk of contracting HBV. Your doctor should test you for HBV. Humira can cause reactivation of HBV in people who carry this virus. In some rare cases, especially if you are taking other medicines that suppress the immune system, reactivation of HBV can be life-threatening.
- If you are over 65 years you may be more susceptible to infections while taking Humira. You and your doctor should pay special attention to signs of infection while you are being treated with Humira. It is important to tell your doctor if you get symptoms of infections, such as fever, wounds, feeling tired or dental problems.
- If you are about to undergo surgery or dental procedures please inform your doctor that you are taking Humira. Your doctor may recommend temporary discontinuation of Humira.
- If you have or develop demyelinating disease such as multiple sclerosis, your doctor will decide if you should receive or continue to receive Humira. Tell your doctor immediately if you experience symptoms like changes in your vision, weakness in your arms or legs or numbness or tingling in any part of your body.
- Certain vaccines may cause infections and should not be given while receiving Humira. Please check with your doctor before you receive any vaccines. It is recommended that children, if possible, be brought up to date with all immunisations in agreement with current immunisation guidelines prior to initiating Humira therapy. If you received Humira while you were pregnant, your baby may be at higher risk for getting such an infection for up to approximately five months after the last dose you received during pregnancy. It is important that you tell your baby's doctors and other health care professionals about your Humira use during your pregnancy so they can decide when your baby should receive any vaccine.
- If you have mild heart failure and you are being treated with Humira, your heart failure status must be closely monitored by your doctor. It is important to tell your doctor if you have had or have a serious heart condition. If you develop new or worsening symptoms of heart failure (e.g. shortness of breath, or swelling of your feet), you must contact your doctor immediately. Your doctor will decide if you should receive Humira.
- In some patients the body may fail to produce enough of the blood cells that help your body fight infections or help you to stop bleeding. If you develop a fever that does not go away,

bruise or bleed very easily or look very pale, call your doctor right away. Your doctor may decide to stop treatment.

- There have been very rare cases of certain kinds of cancer in children and adult patients taking Humira or other TNF blockers. People with more serious rheumatoid arthritis that have had the disease for a long time may have a higher than average risk of getting lymphoma (a kind of cancer that affects the lymph system), and leukemia (a kind of cancer that affects the blood and bone marrow). If you take Humira the risk of getting lymphoma, leukemia, or other cancers may increase. On rare occasions, a specific and severe type of lymphoma, has been observed in patients taking Humira. Some of those patients were also treated with azathioprine or 6-mercaptopurine. Tell your doctor if you are taking azathioprine or 6-mercaptopurine with Humira. In addition cases of non-melanoma skin cancer have been observed in patients taking Humira. If new skin lesions appear during or after therapy or if existing lesions change appearance, tell your doctor.
- There have been cases of cancers, other than lymphoma in patients with a specific type of lung disease called Chronic Obstructive Pulmonary Disease (COPD) treated with another TNF blocker. If you have COPD, or are a heavy smoker, you should discuss with your doctor whether treatment with a TNF blocker is appropriate for you.

### **Children and adolescents**

- Vaccinations: if possible children should be up to date with all vaccinations before using Humira.
- Do not give Humira to children with polyarticular juvenile idiopathic arthritis below the age of 2 years.

### **Other medicines and Humira**

Tell your doctor or pharmacist if you are taking, have recently taken or might take any other medicines.

Humira can be taken together with methotrexate or certain disease-modifying anti-rheumatic agents (sulfasalazine, hydroxychloroquine, leflunomide and injectable gold preparations), steroids or pain medications including non-steroidal anti-inflammatory drugs (NSAIDs).

You should not take Humira with medicines containing the active substance, anakinra or abatacept. If you have questions, please ask your doctor.

### **Humira with food and drink**

Since Humira is injected under the skin (subcutaneously), food and drink should not affect Humira.

### **Pregnancy and breast-feeding**

The effects of Humira in pregnant women are not known and so the use of Humira in pregnant women is not recommended. You are advised to avoid becoming pregnant and must use adequate contraception while using Humira and for at least 5 months after the last Humira treatment. If you become pregnant, you should consult your doctor.

It is not known whether adalimumab passes into breast milk.

If you are a breast-feeding mother, you should stop breast-feeding during Humira treatment and for at least 5 months after the last Humira treatment. If you received Humira during your pregnancy, your baby may have a higher risk for getting an infection. It is important that you tell your baby's doctors

and other health care professionals about your Humira use during your pregnancy before the baby receives any vaccine (for more information see section on vaccination).

If you think you may be pregnant or are planning to have a baby, ask your doctor or pharmacist for advice before taking this medicine.

### **Driving and using machines**

Humira may have a minor influence on your ability to drive, cycle or use machines. Room spinning sensation and vision disturbances may occur after taking Humira.

### **3. How to use Humira**

Always use this medicine exactly as your doctor or pharmacist has told you. Check with your doctor or pharmacist if you are not sure.

#### Adults with rheumatoid arthritis, psoriatic arthritis, ankylosing spondylitis or axial spondyloarthritis without radiographic evidence of ankylosing spondylitis

Humira is injected under the skin (subcutaneous use). The usual dose for adults with rheumatoid arthritis, ankylosing spondylitis, axial spondyloarthritis without radiographic evidence of ankylosing spondylitis, and for patients with psoriatic arthritis is 40 mg adalimumab given every other week as a single dose.

In rheumatoid arthritis, methotrexate is continued while using Humira. If your doctor determines that methotrexate is inappropriate, Humira can be given alone.

If you have rheumatoid arthritis and you do not receive methotrexate with your Humira therapy, your doctor may decide to give 40 mg adalimumab every week.

#### Children with polyarticular juvenile idiopathic arthritis

The recommended dose of Humira for patients with polyarticular juvenile idiopathic arthritis, aged 2 to 12 years depends on the height and weight of the child. Your child's doctor will tell you the correct dose to use.

The recommended dose of Humira for patients with polyarticular juvenile idiopathic arthritis, aged 13 to 17 years, is 40mg every other week.

#### Children with enthesitis-related arthritis

The recommended dose of Humira for patients with enthesitis-related arthritis, aged 6 to 17 years depends on the height and weight of the child.

#### Adults with psoriasis

The usual dose for adults with psoriasis is an initial dose of 80 mg, followed by 40 mg given every other week starting one week after the initial dose. You should continue to inject Humira for as long as your doctor has told you. Depending on your response, your doctor may increase the dose frequency to 40 mg every week.

### Children or adolescents with plaque psoriasis

The recommended dose of Humira for patients aged 4 to 17 years with plaque psoriasis depends on the weight of your child. Your child's doctor will tell you the correct dose to use.

Patients requiring a dose less than 40 mg should use the 40 mg vial presentation of Humira.

### Adults with hidradenitis suppurativa

The usual dose regimen for hidradenitis suppurativa is an initial dose of 160 mg (as 4 injections in one day or 2 injections per day for two consecutive days), followed by an 80 mg dose (as 2 injections on the same day) two weeks later. After two further weeks, continue with a dose of 40 mg every week. It is recommended that you use an antiseptic wash daily on the affected areas.

### Adults with Crohn's disease

The usual dose regimen for Crohn's disease is 80 mg initially followed by 40 mg every other week two weeks later. If a faster response is required your doctor may prescribe an initial dose of 160 mg (as 4 injections in one day or 2 injections per day for two consecutive days), followed by 80 mg two weeks later, and thereafter as 40 mg every other week. Depending on your response, your doctor may increase the dose frequency to 40 mg every week.

### Children or adolescents with Crohn's disease

#### Children or adolescents weighing less than 40 kg:

The usual dose regimen is 40 mg initially followed by 20 mg two weeks later. If a faster response is required, your doctor may prescribe an initial dose of 80 mg (as 2 injections in 1 day) followed by 40 mg two weeks later.

Thereafter, the usual dose is 20 mg every other week. Depending on your response, your doctor may increase the dose frequency to 20 mg every week.

#### Children or adolescents weighing 40 kg or more:

The usual dose regimen is 80 mg initially followed by 40 mg two weeks later. If a faster response is required, your doctor may prescribe an initial dose of 160 mg (as 4 injections in 1 day or as 2 injections per day for 2 consecutive days) followed by 80 mg two weeks later.

Thereafter, the usual dose is 40mg every other week. Depending on your response, your doctor may increase the dose frequency to 40 mg every week.

Patients requiring a dose less than 40 mg should use the 40mg vial presentation of Humira.

### Adults with ulcerative colitis

The usual Humira dose for adults with ulcerative colitis is 160 mg at Week 0 (dose can be administered as four injections in one day or as two injections per day for two consecutive days) and 80 mg at Week 2, and thereafter 40 mg every other week. Depending on your response, your doctor may increase the dose to 40 mg every week.

### Adults with non-infectious uveitis

The usual dose for adults with non-infectious uveitis is an initial dose of 80 mg, followed by 40 mg given every other week starting one week after the initial dose. You should continue to inject Humira for as long as your doctor has told you.

In non-infectious uveitis, corticosteroids or other medicines that influence the immune system may be continued while using Humira. Humira can also be given alone.

### Method and route of administration

Humira is administered by injection under the skin (by subcutaneous injection).

### Injecting Humira yourself

The following instructions explain how to give yourself an injection of Humira using the pre-filled pen. Please read the instructions carefully and follow them step by step. You will be instructed by your doctor or his/her assistant on the technique of self-injection. Do not attempt to self-inject until you are sure that you understand how to prepare and give the injection. After proper training, the injection can be self-administered or given by another person, for example a family member or friend.

### What should I do before I give myself a subcutaneous injection of Humira?

1. Wash your hands thoroughly.
2. Take one dose tray containing a pre-filled pen of Humira from the refrigerator.
3. Do not shake or drop the pre-filled pen.
4. Set up the following items on a clean surface.

- One pre-filled pen of Humira
- One alcohol pad

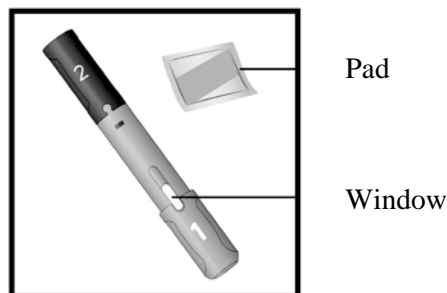

5. Check the expiry date on the pre-filled pen label (EXP:) Do not use the product if the date has passed the month and year shown.
6. Hold the pre-filled pen with the grey cap (labelled '1') pointing up. Check the appearance of the Humira solution through the window on the sides of the pre-filled pen. It must be clear and colourless. If it is cloudy or discoloured or has flakes or particles in it, you must not use it. Do not use a pre-filled pen that is frozen or if it has been left in direct sunlight. Only remove both the grey cap and the plum cap **immediately** before injection

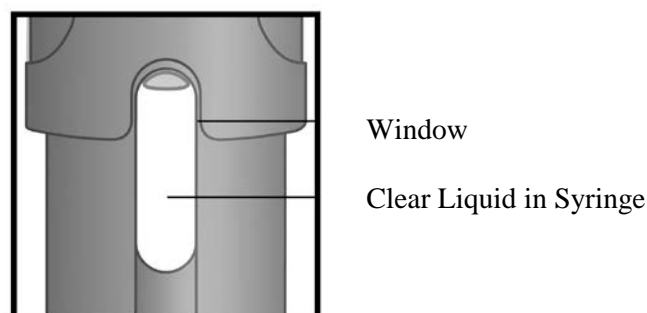



### Where should I give my injection?

1. Choose a site on the top of your thigh or stomach (except the area around the navel).

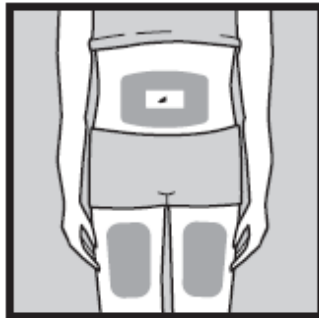

2. Change the place that you inject each time so that you do not become sore in one area. Each new injection should be given at least 3 cm from the last injection site.
3. Do not inject in an area where the skin is reddened, bruised, or hard. This may mean there is an infection.

### How do I give my injection?

1. Wipe your skin by using the enclosed alcohol pad, using a circular motion. Do not touch the area again before injecting.
2. Only remove both the grey cap and the plum cap **immediately** before injection. Hold the grey body of the pre-filled pen with one hand. Place hand on the middle of the pen so that neither the grey cap (1) nor the plum cap (2) is covered. Hold the pre-filled pen with the grey cap (1) pointing up. With your other hand, pull the grey cap (1) straight off, check that the small black needle cover of the syringe has been removed with the cap, then discard cap. If a few small drops of liquid come out of the needle, that is okay. The white needle sleeve will now be exposed. Do not try to touch the needle housed in the barrel. **DO NOT RECAP** as you may damage the needle inside.

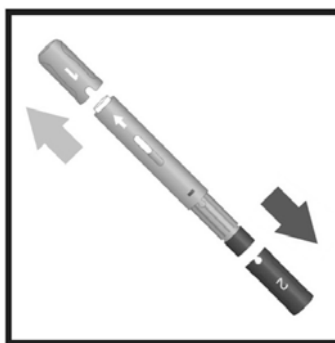

3. Pull the plum safety cap (labelled '2') straight off to expose the plum coloured activation button. The pre-filled pen is now ready to use. Do not press the plum activation button until properly positioned as this will result in discharge of medication. **DO NOT RECAP as this could cause the unit to discharge.**

### Giving the injection

1. With your free hand, gently grasp a sizable area of the cleaned skin at the injection site and hold firmly (see below).

2. Place the white end of the pre-filled pen at a right angle (90 degrees) to the skin, so that you can see the window. The presence of one or more bubbles in the window is normal.
3. Holding the barrel of the pre-filled pen, press down slightly onto the injection site (holding in place without moving).
4. With your index finger or your thumb, press the plum coloured button on top once you are ready to begin the injection (see below). You will then hear a loud 'click' as the needle is released, and you will feel a small prick as the needle advances.
5. Keep pressing and continue to hold the pre-filled pen with steady pressure in place for about **10 seconds to ensure a complete injection**. Do not remove the pre-filled pen while the injection is being given.

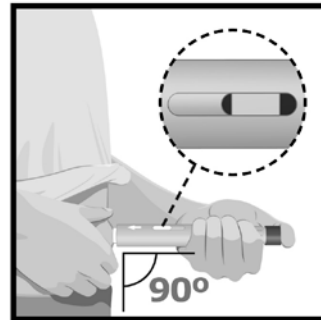
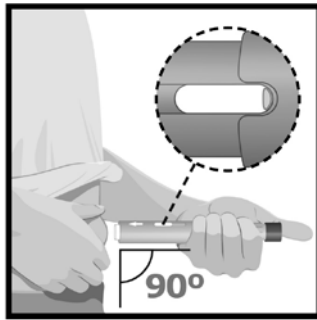

6. You will see a yellow indicator move into the window during the injection. The injection is complete when the yellow indicator stops moving. The yellow indicator is part of the plunger of the pre-filled pen. If the yellow indicator is not shown in the window, the plunger has not advanced adequately, and the injection is not complete.
7. Lift the pre-filled pen straight up from the injection site. The white needle sleeve will move down over the needle and lock into place over the needle tip. Do not try to touch the needle. The white needle sleeve is there to protect you from touching the needle.

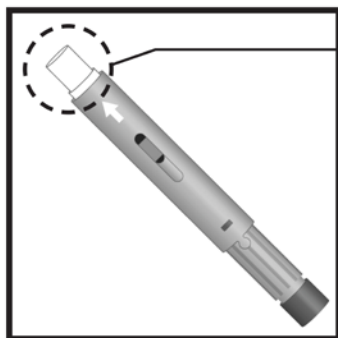

White Needle Sleeve

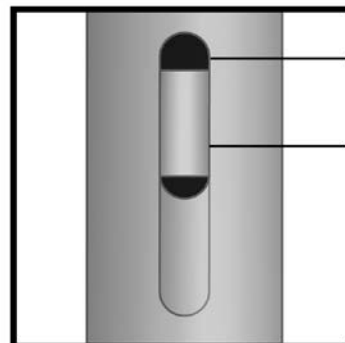

Window

Yellow Indicator Visible

8. You may notice a spot of blood at the injection site. You can press a cotton ball or a piece of gauze over the injection site for 10 seconds. Do not rub the injection site. Use a plaster if you want to.

### Throwing away supplies

- Only use each pre-filled pen for one injection. Do not put either of the caps back on the pre-filled pen
- After injecting Humira, immediately throw away the used pre-filled pen in a special container as instructed by your doctor, nurse or pharmacist
- Keep this container out of the sight and reach of children

**If you use more Humira than you should:**

If you accidentally inject Humira more frequently than told to by your doctor or pharmacist, you should call your doctor or pharmacist and tell him/her that you have taken more. Always take the outer carton of the medicine with you, even if it is empty.

**If you forget to use Humira:**

If you forget to give yourself an injection, you should inject the next dose of Humira as soon as you remember. Then take your next dose as you would have on your originally scheduled day, had you not forgotten a dose.

**If you stop using Humira:**

The decision to stop using Humira should be discussed with your doctor. Your symptoms may return upon discontinuation.

If you have any further questions on the use of this product, ask your doctor or pharmacist.

**4. Possible side effects**

Like all medicines, this medicine can cause side effects, although not everybody gets them. Most side effects are mild to moderate. However, some may be serious and require treatment. Side effects may occur at least up to 4 months after the last Humira injection.

Tell your doctor immediately if you notice any of the following:

- Severe rash, hives or other signs of allergic reaction;
- Swollen face, hands, feet;
- Trouble breathing, swallowing;
- Shortness of breath with exertion or upon lying down or swelling of the feet.

Tell your doctor as soon as possible if you notice any of the following:

- Signs of infection such as fever, feeling sick, wounds, dental problems, burning on urination;
- Feeling weak or tired;
- Coughing;
- Tingling;
- Numbness;
- Double vision;
- Arm or leg weakness;
- A bump or open sore that doesn't heal;
- Signs and symptoms suggestive of blood disorders such as persistent fever, bruising, bleeding, paleness.

The symptoms described above can be signs of the below listed side effects, which have been observed with Humira:

Very common (may affect more than 1 in 10 people):

- injection site reactions (including pain, swelling, redness or itching);
- respiratory tract infections (including cold, runny nose, sinus infection, pneumonia);
- headache;
- abdominal pain;
- nausea and vomiting;
- rash;

- musculoskeletal pain.

Common (may affect up to 1 in 10 people):

- serious infections (including blood poisoning and influenza);
- skin infections (including cellulitis and shingles);
- ear infections;
- oral infections (including tooth infections and cold sores);
- reproductive tract infections;
- urinary tract infection);
- fungal infections;
- joint infections;
- benign tumours;
- skin cancer;
- allergic reactions (including seasonal allergy);
- dehydration;
- mood swings (including depression);
- anxiety;
- difficulty sleeping;
- sensation disorders such as tingling, prickling or numbness;
- migraine;
- nerve root compression (including low back pain and leg pain);
- vision disturbances;
- eye inflammation;
- inflammation of the eye lid and eye swelling;
- vertigo;
- sensation of heart beating rapidly;
- high blood pressure;
- flushing;
- haematoma;
- cough;
- asthma;
- shortness of breath;
- gastrointestinal bleeding;
- dyspepsia (indigestion, bloating, heart burn);
- acid reflux disease;
- sicca syndrome (including dry eyes and dry mouth);
- itching;
- itchy rash;
- bruising;
- inflammation of the skin (such as eczema);
- breaking of finger nails and toe nails;
- increased sweating;
- hair loss;
- new onset or worsening of psoriasis;
- muscle spasms;
- blood in urine;
- kidney problems;
- chest pain;
- oedema;
- fever;
- reduction in blood platelets which increases risk of bleeding or bruising;
- impaired healing.

Uncommon (may affect up to 1 in 100 people):

- opportunistic infections (which include tuberculosis and other infections that occur when resistance to disease is lowered);
- neurological infections (including viral meningitis);
- eye infections;
- bacterial infections;
- diverticulitis (inflammation and infection of the large intestine);
- cancer;
- cancer that affects the lymph system;
- melanoma;
- immune disorders that could affect the lungs, skin and lymph nodes (most commonly presenting as sarcoidosis);
- vasculitis (inflammation of blood vessels);
- tremor;
- neuropathy;
- stroke;
- double vision;
- hearing loss, buzzing;
- sensation of heart beating irregularly such as skipped beats;
- heart problems that can cause shortness of breath or ankle swelling;
- heart attack;
- a sac in the wall of a major artery, inflammation and clot of a vein, blockage of a blood vessel;
- lung diseases causing shortness of breath (including inflammation);
- pulmonary embolism (blockage in an artery of the lung);
- pleural effusion (abnormal collection of fluid in the pleural space);
- inflammation of the pancreas which causes severe pain in the abdomen and back;
- difficulty in swallowing;
- facial oedema;
- gallbladder inflammation, gallbladder stones;
- fatty liver;
- night sweats;
- scar;
- abnormal muscle breakdown;
- systemic lupus erythematosus (including inflammation of skin, heart, lung, joints and other organ systems);
- sleep interruptions;
- impotence;
- inflammations.

Rare (may affect up to 1 in 1,000 people)

- leukemia (cancer affecting the blood and bone marrow);
- severe allergic reaction with shock;
- multiple sclerosis;
- nerve disorders (such as eye nerve inflammation and Guillain-Barré syndrome that may cause muscle weakness, abnormal sensations, tingling in the arms and upper body);
- heart stops pumping;
- pulmonary fibrosis (scarring of the lung);
- intestinal perforation;
- hepatitis;
- reactivation of hepatitis B;
- autoimmune hepatitis (inflammation of the liver caused by the body's own immune system);
- cutaneous vasculitis (inflammation of blood vessels in the skin);
- Stevens-Johnson syndrome (early symptoms include malaise, fever, headache and rash);

- facial oedema associated with allergic reactions;
- erythema multiforme (inflammatory skin rash);
- lupus-like syndrome.

Not known (frequency cannot be estimated from available data):

- hepatosplenic T-cell lymphoma (a rare blood cancer that is often fatal);
- Merkel cell carcinoma (a type of skin cancer);
- liver failure;
- worsening of a condition called dermatomyositis (seen as a skin rash accompanying muscle weakness).

Some side effects observed with Humira may not have symptoms and may only be discovered through blood tests. These include:

Very common (may affect more than 1 in 10 people)

- low blood measurements for white blood cells;
- low blood measurements for red blood cells;
- increased lipids in the blood;
- elevated liver enzymes.

Common (may affect up to 1 in 10 people):

- high blood measurements for white blood cells;
- low blood measurements for platelets;
- increased uric acid in the blood;
- abnormal blood measurements for sodium;
- low blood measurements for calcium;
- low blood measurements for phosphate;
- high blood sugar;
- high blood measurements for lactate dehydrogenase;
- autoantibodies present in the blood.

Rare (may affect up to 1 in 1,000 people):

- low blood measurements for white blood cells, red blood cells and platelet count.

Not known (frequency cannot be estimated from the available data):

- liver failure.

#### Reporting of side effects

If you get any side effects, talk to your doctor or pharmacist. This includes any possible side effects not listed in this leaflet. You can also report side effects directly via the national reporting system listed below. By reporting side effects, you can help provide more information on the safety of this medicine.

#### **United Kingdom**

Yellow Card Scheme

Website: [www.mhra.gov.uk/yellowcard](http://www.mhra.gov.uk/yellowcard)

## **Ireland**

HPRA Pharmacovigilance  
Earlsfort Terrace  
IRL – Dublin 2  
Tel: +353 1 6764971  
Fax: +353 1 6762517  
Website: [www.hpra.ie](http://www.hpra.ie)  
E-mail: [medsafety@hpra.ie](mailto:medsafety@hpra.ie)

## **Malta**

ADR Reporting  
Website: [www.medicinesauthority.gov.mt/adrportal](http://www.medicinesauthority.gov.mt/adrportal)

## **5. How to store Humira**

Keep this medicine out of the sight and reach of children.

Do not use this medicine after the expiry date stated on the label/blister/carton after EXP. The expiry date refers to the last day of that month.

Store in a refrigerator (2°C – 8°C). Do not freeze.

Keep the pre-filled pen in the outer carton in order to protect from light.

Alternative Storage:

When needed (for example when you are travelling), a single Humira pre-filled pen may be stored at room temperature (up to 25°C) for a maximum period of 14 days – be sure to protect it from light. Once removed from the refrigerator for room temperature storage, the pen **must be used within 14 days or discarded**, even if it is returned to the refrigerator.

You should record the date when the pen is first removed from refrigerator, and the date after which it should be discarded.

Do not throw away any medicines via wastewater or household waste. Ask your doctor or pharmacist how to throw away medicines you no longer use. These measures will help protect the environment.

## **6. Contents of the pack and other information**

### **What Humira contains**

The active substance is adalimumab.

The other ingredients are mannitol, polysorbate 80 and water for injections.

This medicinal product contains less than 1 mmol of sodium (23 mg) per 0.4 ml dose, i.e. essentially 'sodium-free' and does not contain preservatives.

### **What the Humira pre-filled pen looks like and contents of the pack**

Humira 40 mg solution for injection in pre-filled pen is supplied as a sterile solution of 40 mg adalimumab dissolved in 0.4 ml solution.

The Humira pre-filled pen is a single-use grey- and plum-coloured pen which contains a glass syringe with Humira. There are two caps – one is grey and labelled '1' and the other is plum and labelled '2'.

There is a window on each side of the pen through which you can see the Humira solution inside the syringe.

The Humira pre-filled pen is available in packs containing 1, 2, 4, and 6 pre-filled pens. The 1 pre-filled pen pack comes with 2 alcohol pads (1 spare). For the 2, 4, and 6 pre-filled pen packs, each pre-filled pen comes with 1 alcohol pad. Not all pack sizes may be marketed.

Humira is available as a vial, a pre-filled syringe and a pre-filled pen.

### **Marketing Authorisation Holder**

AbbVie Ltd  
Maidenhead  
SL6 4UB  
United Kingdom

### **Manufacturer**

AbbVie Biotechnology GmbH  
Knollstrasse  
67061 Ludwigshafen  
Germany

For any information about this medicine, please contact the local representative of the Marketing Authorisation Holder.

### **Ireland**

AbbVie Limited  
Tel: +353 (0)1 4287900

### **Malta**

V.J. Salomone Pharma Limited  
Tel: +356 22983201

### **United Kingdom**

AbbVie Ltd  
Tel: +44 (0)1628 561090

**This leaflet was last revised in 06 2016.**

Detailed information on this medicine is available on the European Medicines Agency web site:  
<http://www.ema.europa.eu>.